

PART NAME: ADJUSTMENT KNOB SCALE: 2:1 DATE: 9/4/96 DR. BY HD

THIS DRAWING IS THE PROPERTY OF DAVIES MOLDING COMPANY, IS SUBMITTED SOLELY AS A DESIGN OR ENGINEERING PROJECT. WE ACCEPT NO RESPONSIBILITY WHATSOEVER FOR THE PRACTICAL APPLICATION OF THE PIECES MADE TO THIS DESIGN.

DAVIES MOLDING DESIGNERS & MANUFACTURERS OF KNOBS, HANDLES, CASES & CUSTOM PLASTIC COMPONENTS

P/N 3084-K	
MOLD NO. 3084	
CAVITY	3084
CORE	3084
EJCT. SLEEVE	3084
PIN	3084-K
INSERT	I2026
TOP PINS	SHORT (1.272)

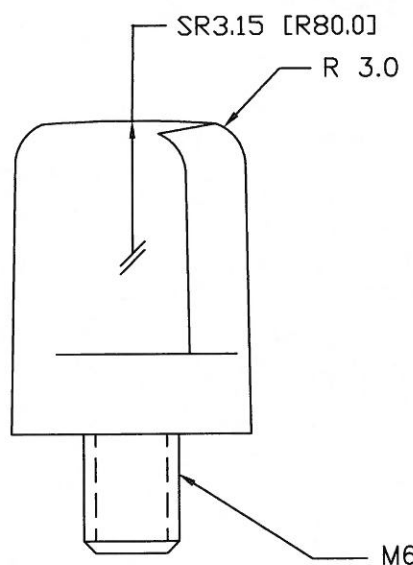
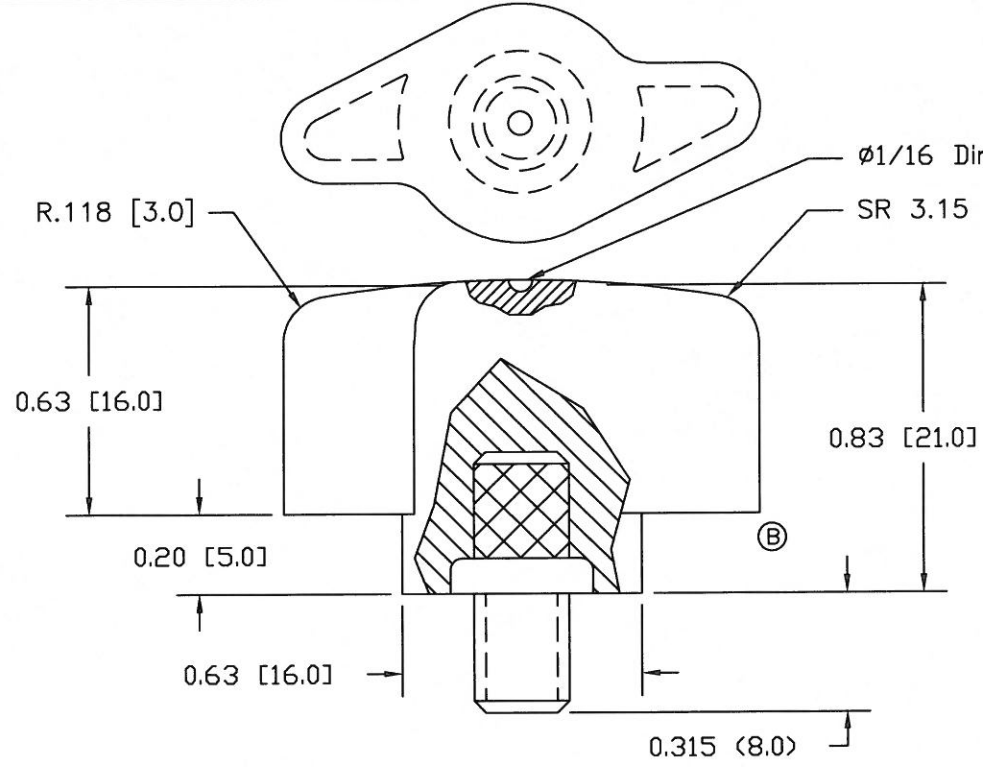

M6 X 1.0 - 6g.
I2026, STEEL, ZINC PLATED.

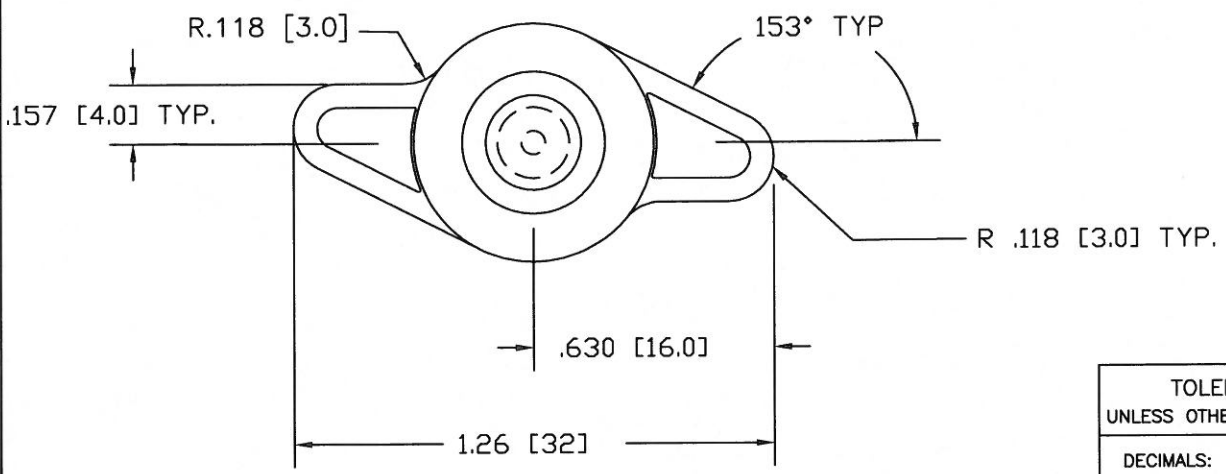

NOTE(S) :
(1) ALL EXTERNAL SURFACES TO BE RAWAL TEXTURE (MT-11010)

MATERIAL : HIPS
COLOR : BLACK

TOLERANCES: UNLESS OTHERWISE SPECIFIED	DO NOT SCALE DRAWING	B	REMOVED RADIUS	JAM	11/23/09
DECIMALS: X.XXX ± .005 X.XX ± .015	MM: X.XX ± 0.15MM X.X ± 0.4MM	A	Added Dimple	TS	8/6/98
FRACTIONS ± 1/64	ANG. ± 1°	-	WAS SK920-1.DWG, WAS P/N 3084-K-1	HD	9/4/96
CHANGES					