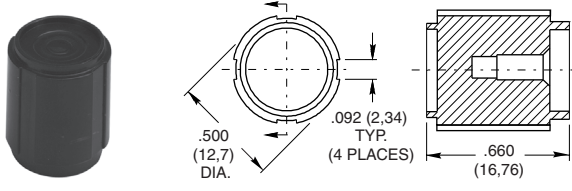
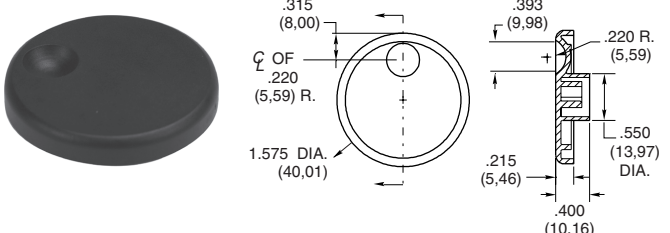
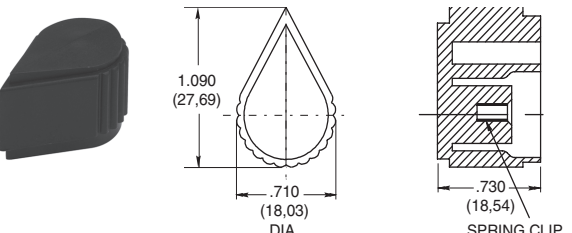
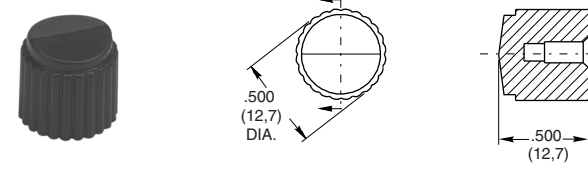

DIMENSIONS In inches (and millimeters)

<p>Style 5019</p> 	<p>Style 5020</p>  <p>Available in ABS, .250 dia. shaft in spring clip (press-on). The locking clip is also available, requires a custom shaft.**</p>
<p>Style 5028</p> 	<p>Style 5029</p> 

*See Ordering Information.

**Contact Grayhill representative

ORDERING INFORMATION

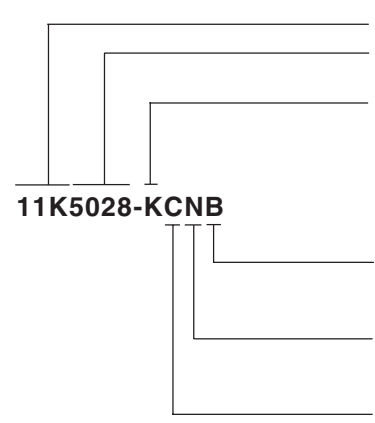

11K5028-KCNB

Series
Style*: 5013, 5014, 5015, 5017, 5019, 5020, 5028, 5029
 (see dimension drawings for style options)

Shaft Diameter:
J = .125 dia. shaft
E = .157 (4mm) dia. shaft
K = .250 dia. shaft

Knob Color:
B = Black
G = Gray

Material:
A = ABS (available on the styles 5017 and 5020 only)
N = Nylon

Version:
C = Spring Clip (press-on)
L = Locking Clip (available on the style 5020 only)
M = Metal Insert w/Set Screw(s)

Custom materials, styles and colors are available.

For prices and discounts, contact a local sales office or Grayhill.

Optical and Mechanical Encoders